



Utveckling av simulator för ärendehanteringssystem

Sammy Saldjoghi

Niclas Hanold



Inledning

- Allmänt
- Tieto
- Syfte
- Översikt av uppsatsen



Bakgrund

- Ärendehanteringssystem
- Trouble Reports
- Modification Handling (MH)
- ClearQuest (CQ)



MH - CQ

- Schematisk överblick av de nuvarande gränssnitten mellan MHWEB och CQ4E

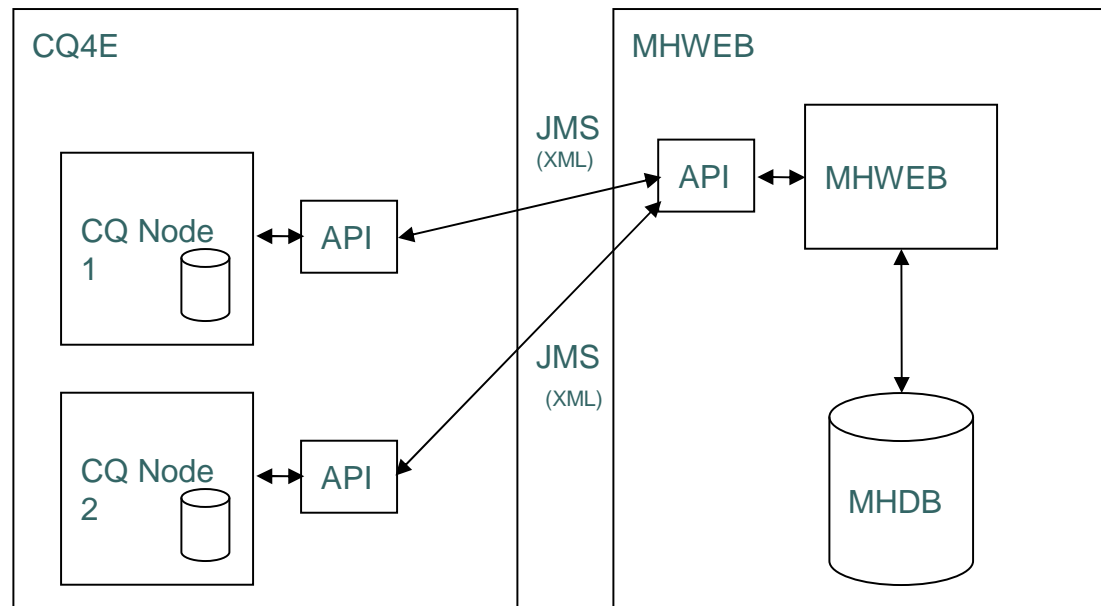



Implementation

- Grafiskt användargränssnitt
- TR-hantering
- Meddelandehantering



GUI

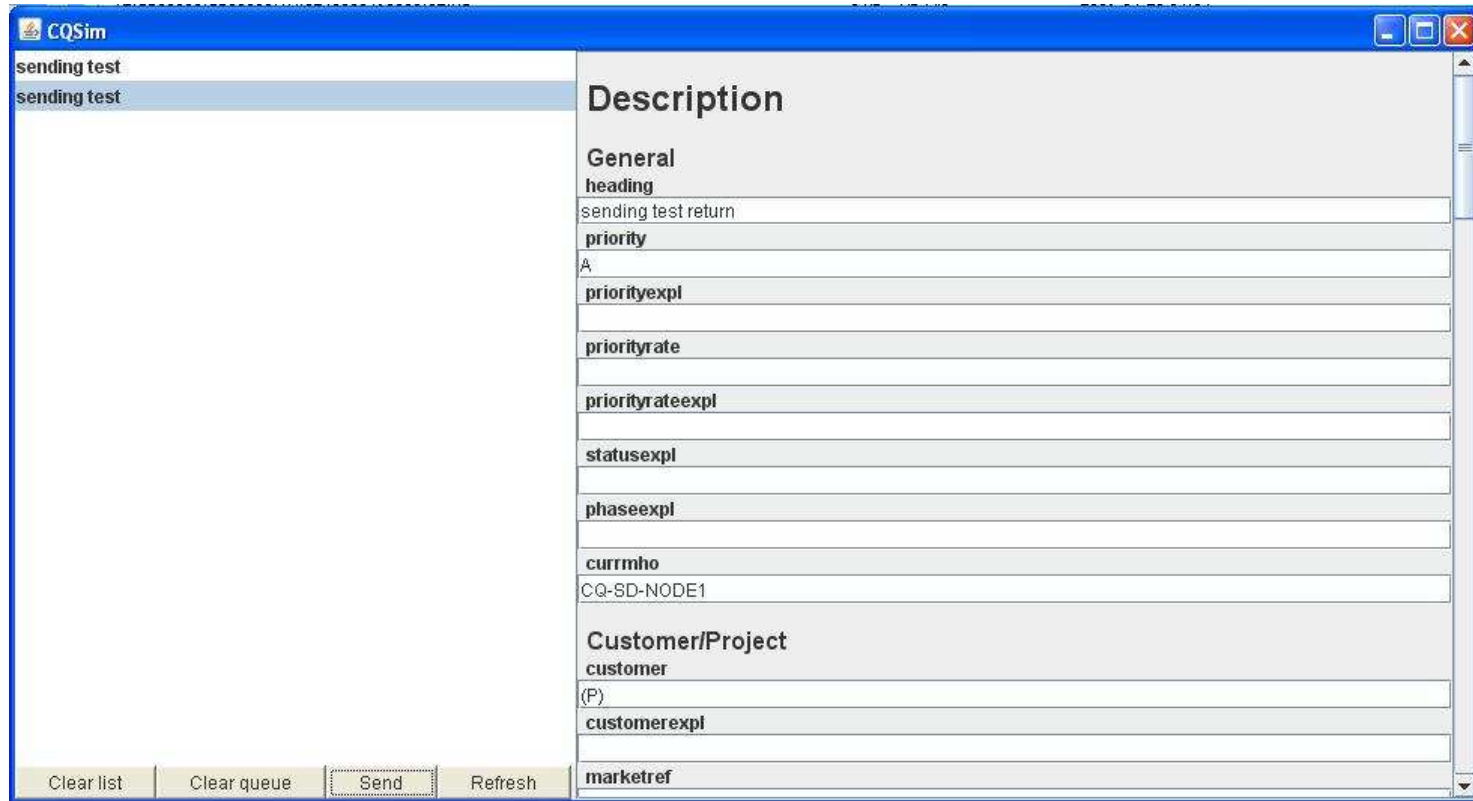



Resultat

- Utvärdering
- Testning



Slutsats

- Nya kunskaper
- Problem
- Framtida utveckling